

“Stay Connected” with



Power Components

a PennEngineering® Company

Heyco® Full Thickness Male Blades BGB and BGMT Series

Blade-Pin-Blade/Blade-Tab-Pin Strip Sequences

NEMA 1-15P & 5-15P – .058" Mold Line Thickness

One shot, one operator, one die terminating!

For mating Female Cord Connectors, see page 8-50.

For Male Ground Pins, see pages 8-39 & 8-40.

For Full Thickness Male/Female Combination Terminals, see pages 8-55 & 8-56.

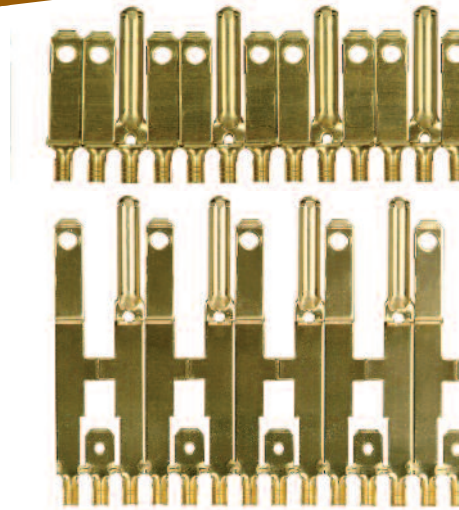

PART DATA			PART NO.		APPLICATION TOOLING*				
Blade Profile	AWG Range	Material	Non-polarized	Polarized	Die**	Feeds	Tool Pack	Crimp Punch	Anvil
BGB Series – Blade-Ground Pin-Blade									
Flat	18-14	Brass	5790	-	5790UXX5	Left to Right	B280L/B281L	C453	C327
7-Shape	18-14	Brass	5792	-	5792UXX5				
		Brass	5793	-	5793UXX5	Right to Left	B280R/B281R		
alternate tooling for above BGB'S:									
	18						B282L/B283L	C798	C327
	16						B284L/B285L	C799	
	14						B286L/B287L	C800	
BGMT Series – Blade-Male Tab-Ground Pin									
Flat	18-14	Brass	5797	-	Consult Heyco	Left to Right	Consult Heyco		

- BGB and BGMT Series Blades feature (3) components on one reel, allowing the operator to attach all three conductors at once for highly efficient **“3-Up” terminating: one shot, one operator, one die.**
- Flat BGB/BGMT Plug Blades are **front loaded** for overmolding.
- Due to their profile, 7-Shape BGB Blades are **side loaded** for overmolding.
- Both BGB and BGMT feature a **unique folded, double-seam** Ground Pin design.
- DFARS Compliant

7-Shape Blades feature a retention ledge to maintain position during overmolding (mold stop).

* Use the Heyco Universal Applicator Die (indicated by “U” in the Die Part No.), page 8-59.

** “XX” represents Wire Gauge. Please specify Wire Gauge when ordering.

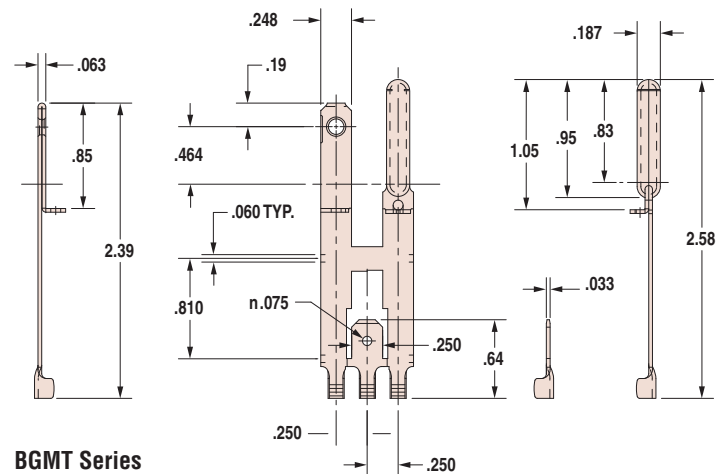
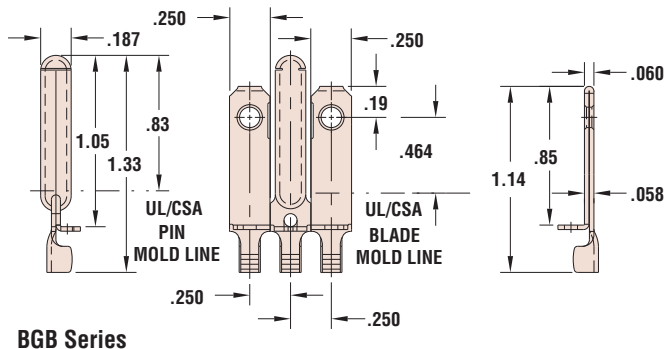

Materials
Certifications
Standards

Alloy 260 Brass (70% Cu, 30% Zn. Higher Cu content resists dezincification)
 Recognized Component under UL File E164169
 Certified by the Canadian Standards Association File 91824
 NEMA 1-15P & NEMA 5-15P

Quick
Specs